

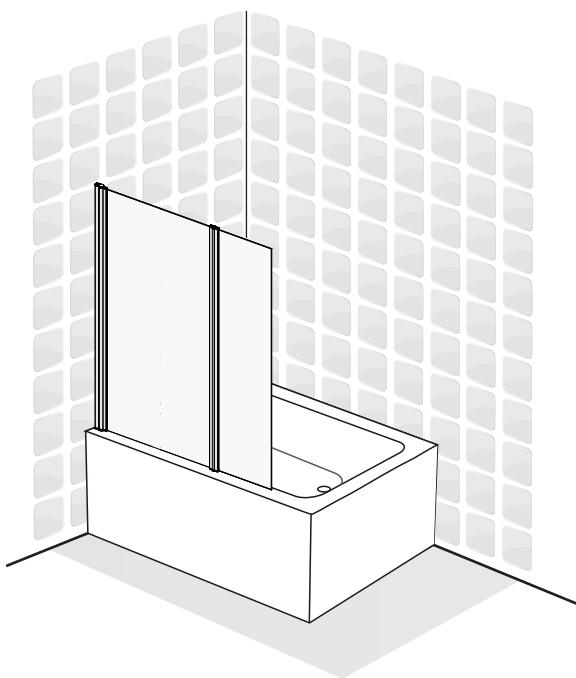

# DADO

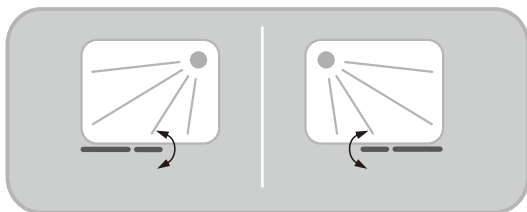

- FR Notice de Montage - Utilisation - Entretien
- ES Instrucciones de Montaje, Utilización y Mantenimiento
- PT Instruções de Montagem, Utilização e Manutenção
- IT Istruzioni per il Montaggio, l'Uso e la Manutenzione
- EL Εγχειρίδιο συναρμολόγησης, χρήσης και συντήρησης
- PL Instrukcja Montażu, Użytkowania i Konserwacji
- RU Руководство По Сборке и Эксплуатации
- UK Керівництво По Збірці і Експлуатації
- RO Manual asamblare, utilizare și întreținere
- EN Assembly - Use - Maintenance Manual



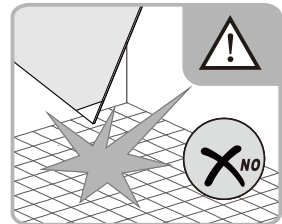
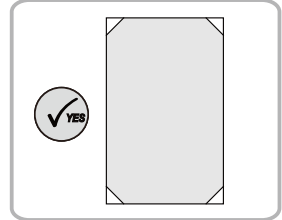
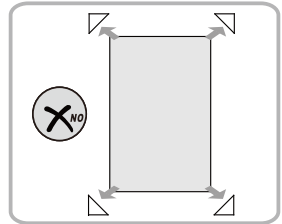
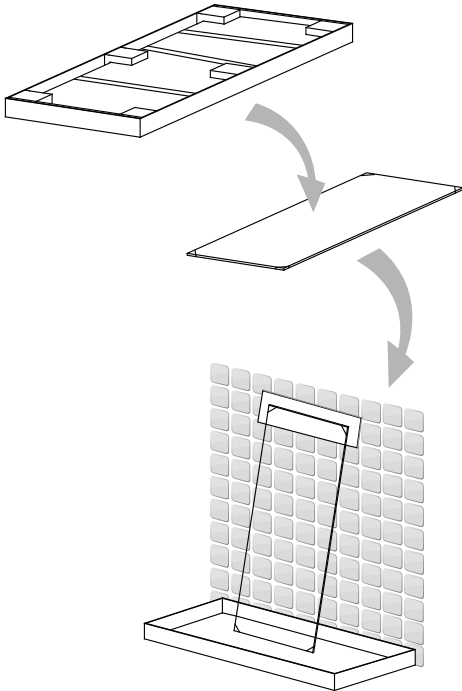
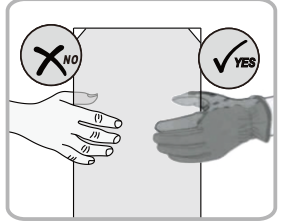
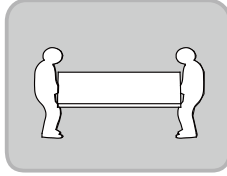
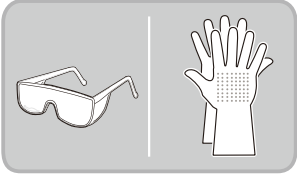
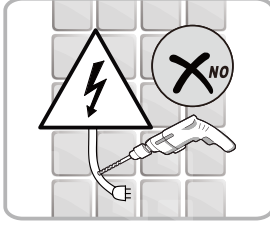
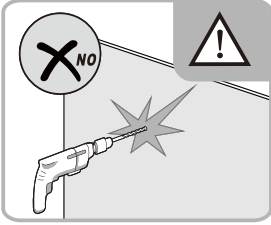

**FR** Vérifiez que les chevilles murales fournies sont appropriées à votre mur (celles fournies dans l'emballage sont conçues pour le béton). Sinon, utilisez des vis et des chevilles murales adaptées au type de matériau de votre mur. Pour obtenir des conseils concernant les vis et les chevilles appropriées à votre mur, demandez à un vendeur spécialisé.

**ES** Compruebe que todos los tacos suministrados puedan ser utilizados con su pared (los incluidos en la caja son para hormigón). En caso contrario, utilice tornillos y tacos de pared apropiados para el material de su pared. Para información acerca de las fijaciones y tornillos apropiados para su pared, consulte con un asistente de ventas especializado.

**PT** Certifique-se de que as buchas fornecidas são adequadas à sua parede (as fornecidas na embalagem são para betão). Caso contrário, use parafusos e buchas adequados ao tipo de material da sua parede. Para se aconselhar acerca dos parafusos e buchas adequados à sua parede, fale com um assistente de vendas especializado.

**IT** Verificare che i tasselli da parete forniti siano compatibili con la propria parete (quelli forniti con l'articolo sono per cemento). Altrimenti, utilizzare viti e tasselli adatti per la superficie della propria parete. Per ottenere consigli e suggerimenti sulle viti e i tasselli più adatti alla propria parete, consultare un rivenditore specializzato.

**EL** Βεβαιωθείτε ότι οι παρεχόμενες στερεώσεις τοίχου είναι κατάλληλες για τον τοίχο σας (οι παρεχόμενες στη συσκευή προορίζονται για μπετόν). Αλλιώς χρησιμοποιήστε βίδες και στερεώσεις τοίχου κατάλληλες για τον τύπο υλικού του τοίχου σας. Για να λάβετε συμβουλές σχετικά με τις κατάλληλες βίδες και τα εξαρτήματα για τον τοίχο σας, ρωτήστε έναν ειδικό πωλητή.

**PL** Prosimy sprawdzić, czy dostarczone kołki do ścian nadają się do użycia w posiadanej ścianie (kołki dostarczone w zestawie są przeznaczone do betonu). Jeśli tak nie jest, należy użyć śrub i kołków odpowiednich do materiału, z którego wykonana jest ściana. Aby uzyskać poradę w sprawie śrub i elementów montażowych odpowiednich do danego typu ściany, należy zwrócić się z pytaniem do wyspecjalizowanego sprzedawcy.

**RU** Убедитесь, что прилагаемые дюбеля подходят для ваших стен (входящие в комплект дюбеля предназначены для бетона). В противном случае используйте шурупы и дюбеля, соответствующие материалу стены. Для получения рекомендаций по выбору шурупов и крепежных деталей, подходящих для вашей стены, обратитесь к специалисту-консультанту.

**UK** Перевірте, що анкери підходять для вашої стіни (ті, що постачаються в упаковці – для бетону). В іншому випадку використовуйте гвинти й стінові анкери, що відповідають матеріалу вашої стіни. Для отримання консультацій щодо гвинтів й фітінгів для вашої стіни зверніться до відповідного продавця-консультанта.

**RO** Verificați ca toate ancorele de perete furnizate să fie adecvate pentru peretele dumneavoastră (cele furnizate în pachet sunt pentru beton). În caz contrar, folosiți șuruburi și ancore de perete adecvate pentru tipul de material din care este peretele dumneavoastră. Pentru a obține recomandări privind șuruburile și armăturile adecvate pentru peretele dumneavoastră, întrebați un vânzător specializat.

**EN** Check that wall anchors provided are suitable for your wall (those provided in the package are for concrete). Otherwise, use screws and wall anchors suited to the type of material of your wall. To obtain advice on the screws and fittings suited to your wall, ask a specialized sales assistant.



Attention danger / Atención: Peligro / Atenção perigo / Attenzione pericolo / Προσοχή κίνδυνος /  
Uwaga niebezpieczeństwo / Внимание! Опасно! / Увага! Небезпечно! / Atenție, pericol / Caution danger



Correct / Correcto / Corretto / Σωστό / Dobrze / Правильный /  
Правильно / Corect / Correct



Incorrect / Incorrecto / Errato / Λάθος / źle / Неправильный /  
Неправильно / Incorect / Incorrect

**Notes / Observaciones / Notas / Note / Σημειώσεις / Notatki / Примечания / Примітки / Note / Notes**

---

---

---

---

---

---

---

FR Préparation

ES Preparación

PT Preparação

IT Preparazione

EL Προετοιμασία

PL Przygotowanie

RU Подготовка

UK Підготування

RO Pregătire

EN Preparation

A

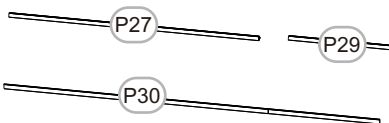
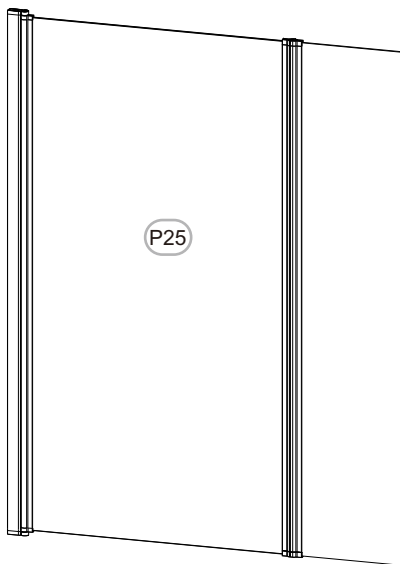
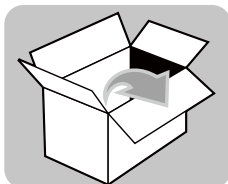

# A

FR Préparation

ES Preparación

PT Preparação

IT Preparazione

EL Προετοιμασία

PL Przygotowanie

RU Подготовка

UK Підготовка

RO Pregătire

EN Preparation

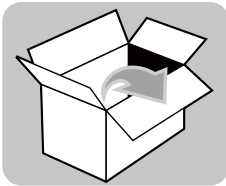

H1



x3

H2

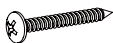

ST4x30mm

x3

H3



ST4x9.5 mm

x3

H14



x3

H15



x3

H24



x1

H25



x1

H26



x1

H27



x1

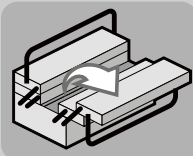

PH2



Ø 6mm

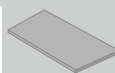
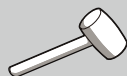

Ø 3mm

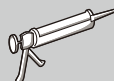
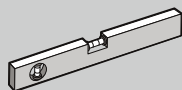
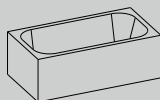

FR Montage

ES Montaje

PT Montagem

IT Montaggio

EL Συναρμολόγηση

PL Montaż

RU Сборка

UK Збірка

RO Montaj

EN Assembly

B

1

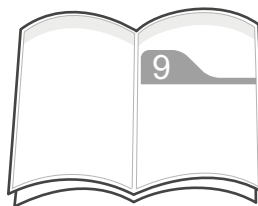
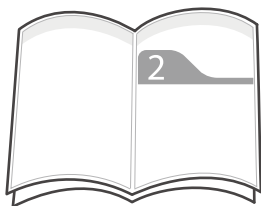
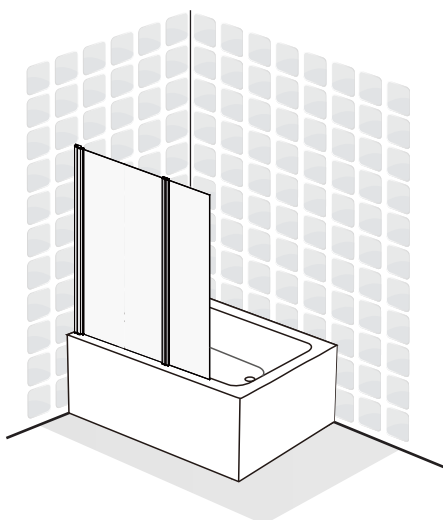
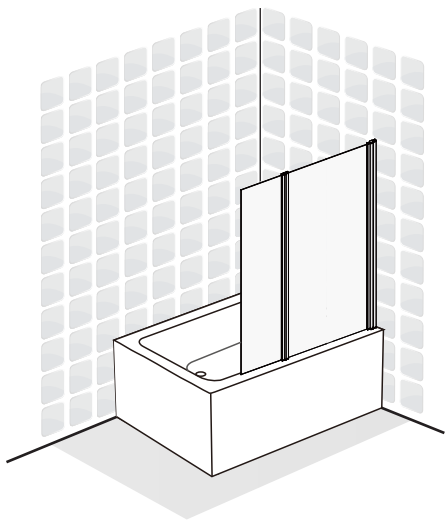

**B**

FR Montage

ES Montaje

PT Montagem

IT Montaggio

EL Συναρμολόγηση

PL Montaż

RU Сборка

UK Збірка

RO Montaj

EN Assembly

2

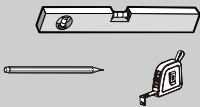
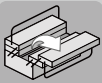
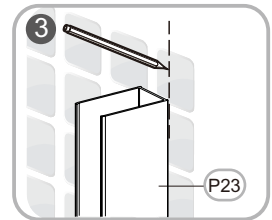
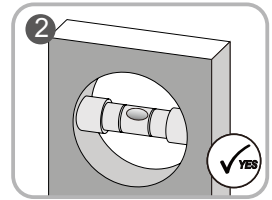
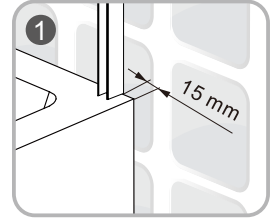
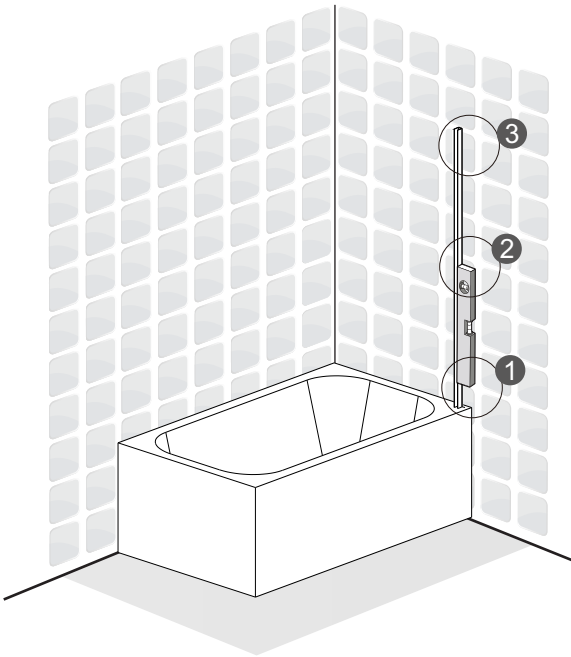
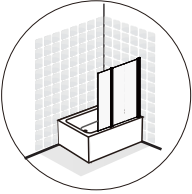

P23



x1





FR Montage

ES Montaje

PT Montagem

IT Montaggio

EL Συναρμολόγηση

PL Montaż

RU Сборка

UK Збірка

RO Montaj

EN Assembly

B

3

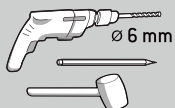
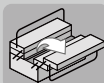
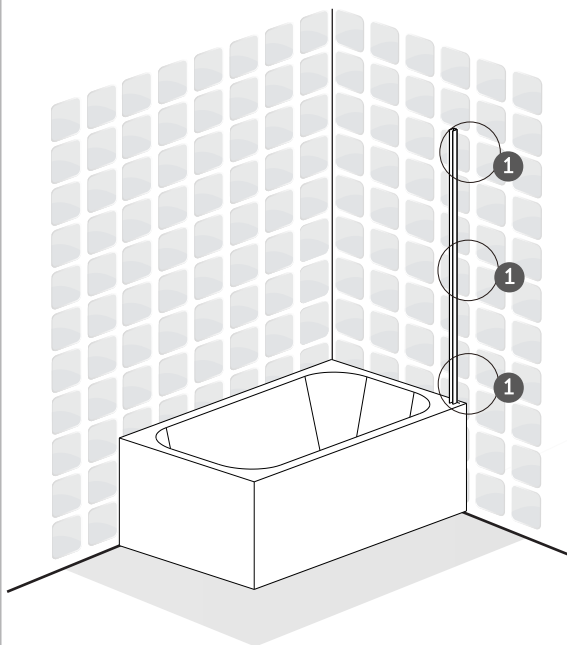
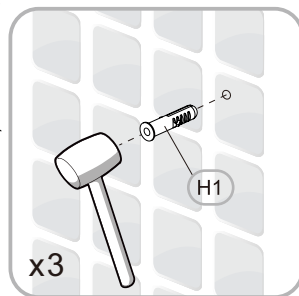
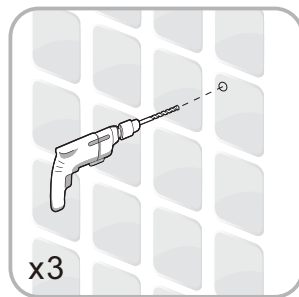
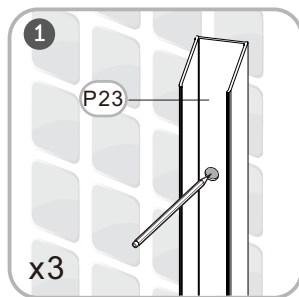
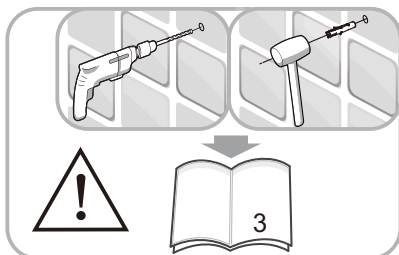
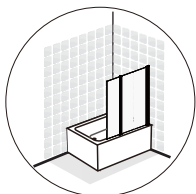

P23  x1

H1  x3



**B**

FR Montage

ES Montaje

PT Montagem

IT Montaggio

EL Συναρμολόγηση

PL Montaż

RU Сборка

UK Збірка

RO Montaj

EN Assembly

4

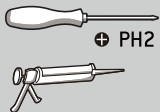
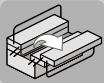
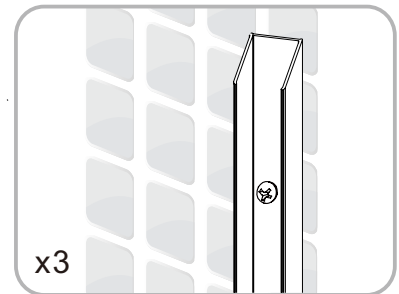
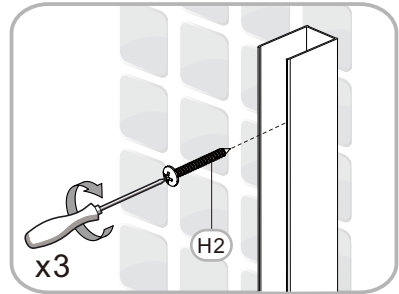
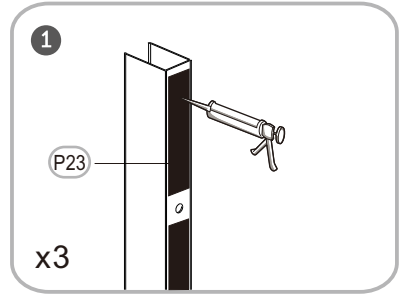
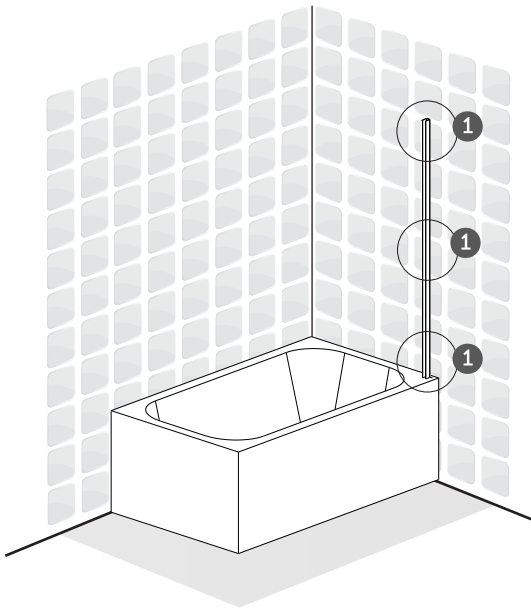
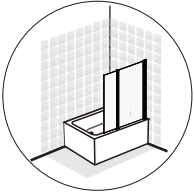

H2



x3



FR Montage

ES Montaje

PT Montagem

IT Montaggio

EL Συναρμολόγηση

PL Montaż

RU Сборка

UK Збірка

RO Montaj

EN Assembly

B

5

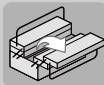
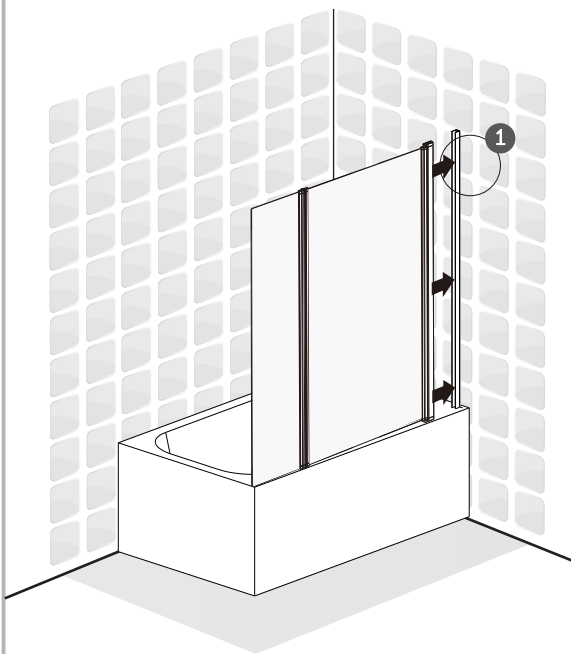
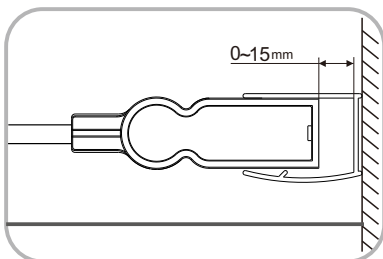
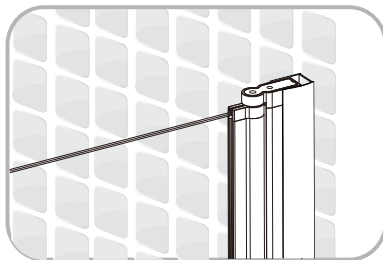
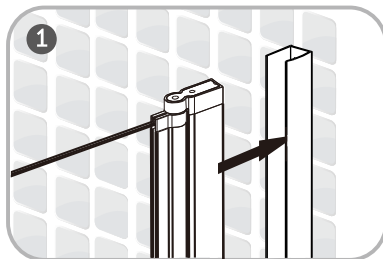
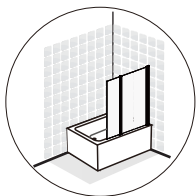

P25



x1



**B**

FR Montage

ES Montaje

PT Montagem

IT Montaggio

EL Συναρμολόγηση

PL Montaż

RU Сборка

UK Збірка

RO Montaj

EN Assembly

6

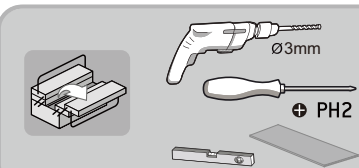
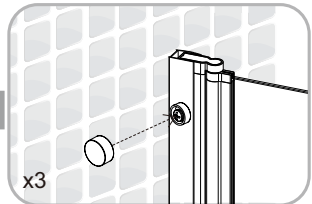
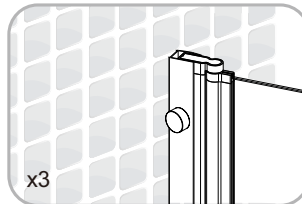
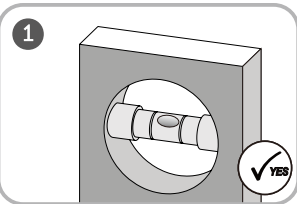
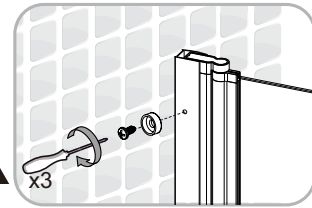
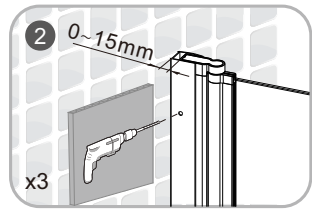
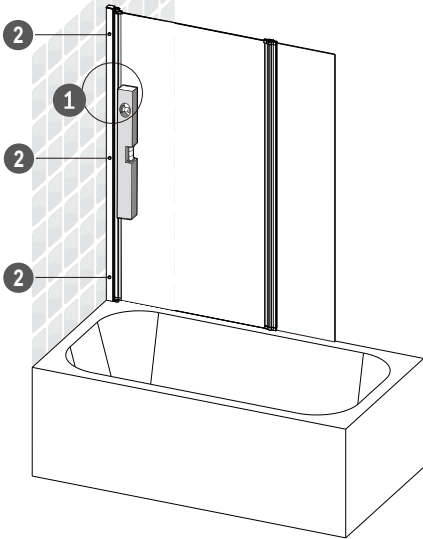
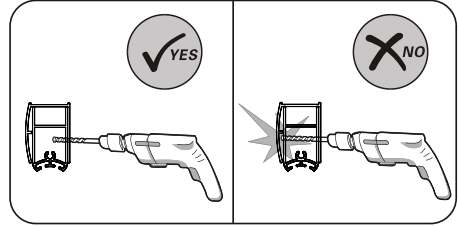
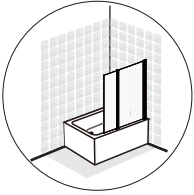

H3



x3

H14



x3

H15



x3



FR Montage

ES Montaje

PT Montagem

IT Montaggio

EL Συναρμολόγηση

PL Montaż

RU Сборка

UK Збірка

RO Montaj

EN Assembly

B

7

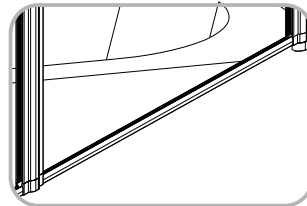
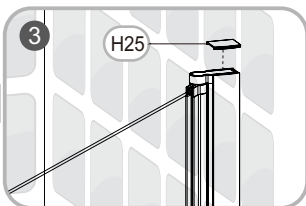
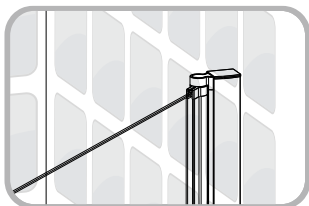
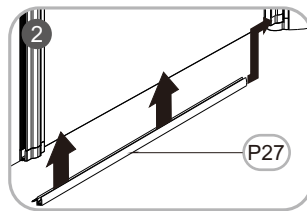
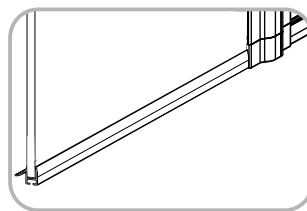
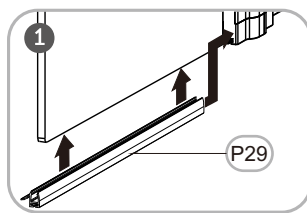
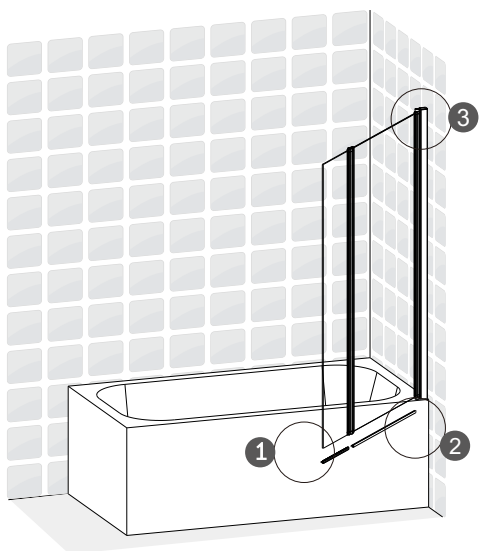
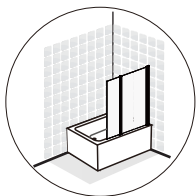

P27  x1

P29  x1

H25  x1



**B**

FR Montage

ES Montaje

PT Montagem

IT Montaggio

EL Συναρμολόγηση

PL Montaż

RU Сборка

UK Збірка

RO Montaj

EN Assembly

8

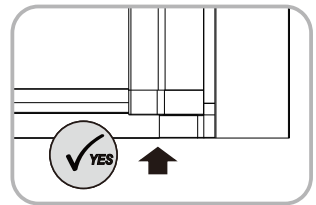
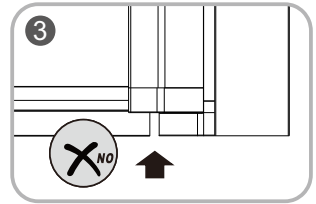
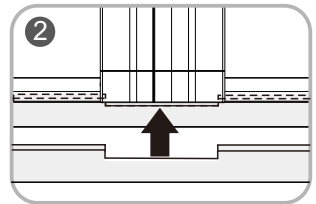
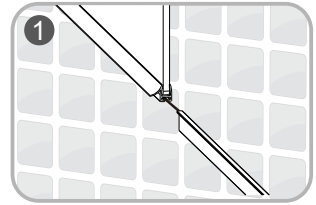
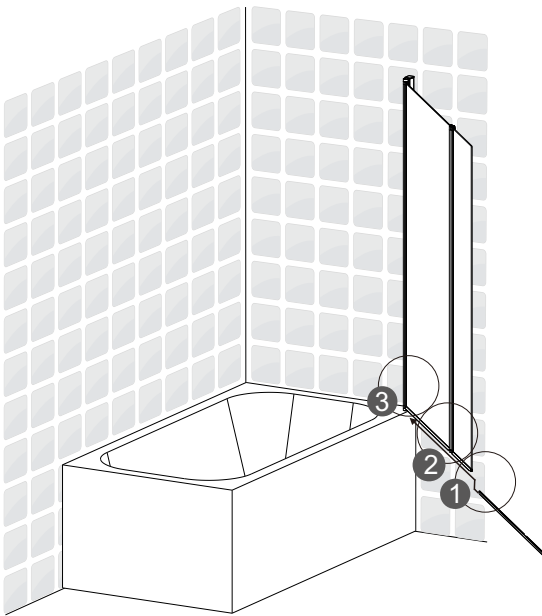
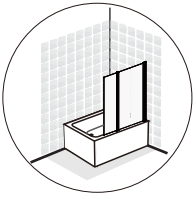

P30



x1



FR Montage

ES Montaje

PT Montagem

IT Montaggio

EL Συναρμολόγηση

PL Montaż

RU Сборка

UK Збірка

RO Montaj

EN Assembly

B

9

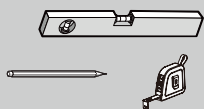
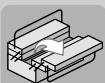
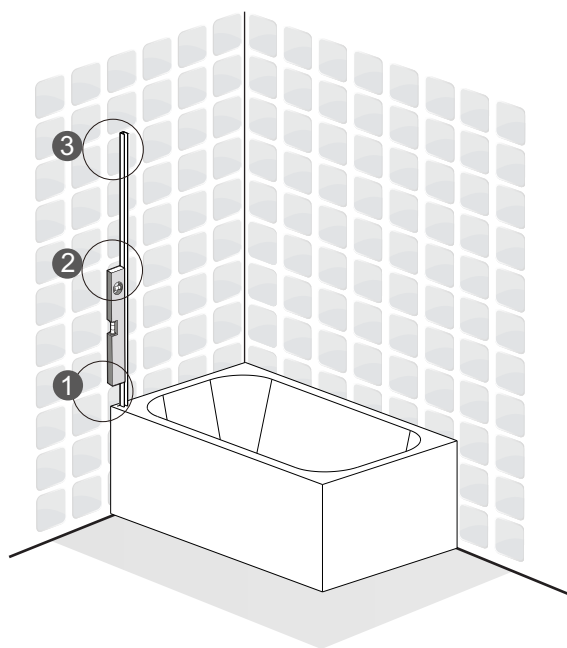
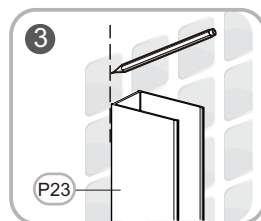
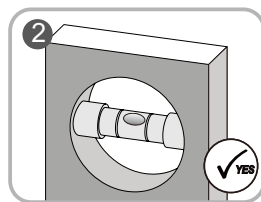
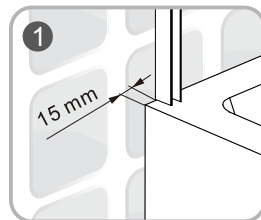
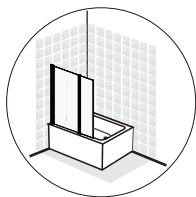

P23

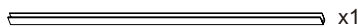

**B****FR** Montage**ES** Montaje**PT** Montagem**IT** Montaggio**EL** Συναρμολόγηση**PL** Montaż**RU** Сборка**UK** Збірка**RO** Montaj**EN** Assembly

10

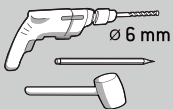
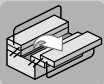
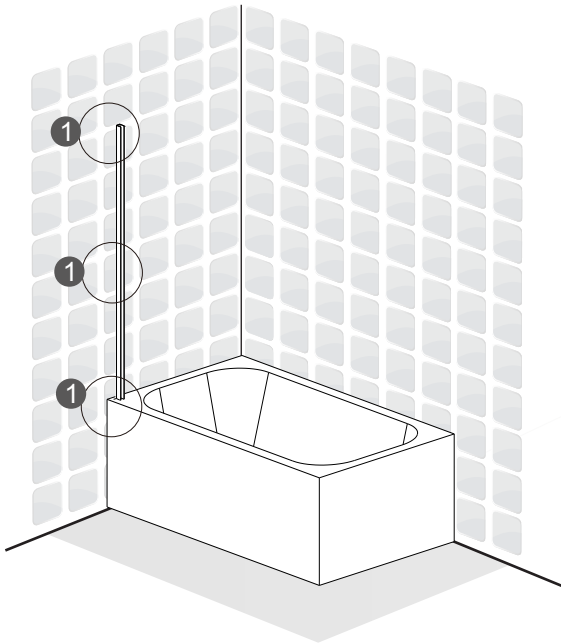
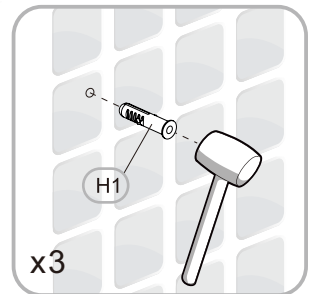
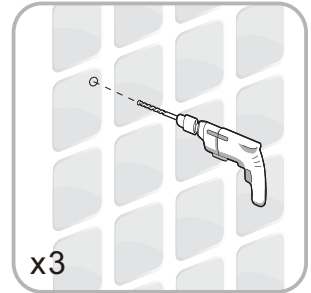
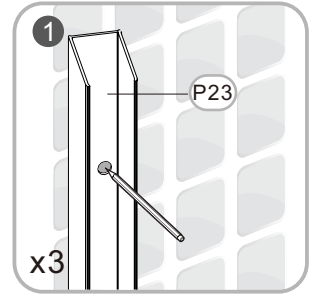
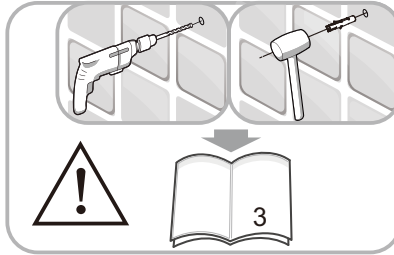
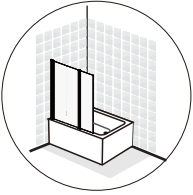

P23

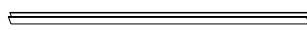

x1

H1



x3





FR Montage

ES Montaje

PT Montagem

IT Montaggio

EL Συναρμολόγηση

PL Montaż

RU Сборка

UK Збірка

RO Montaj

EN Assembly

B

11

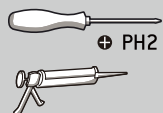
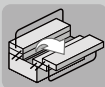
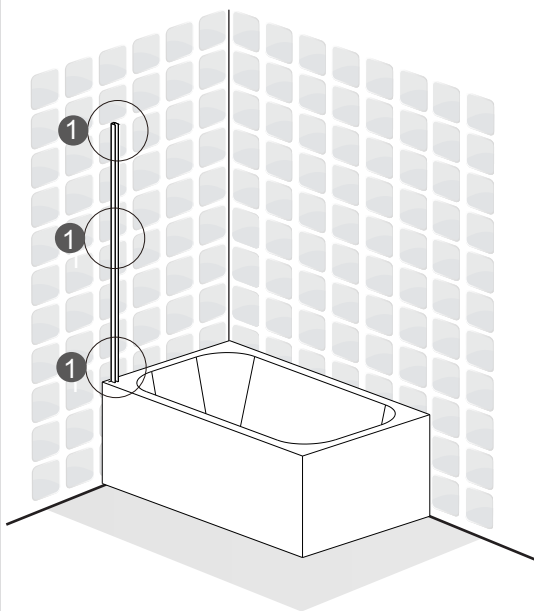
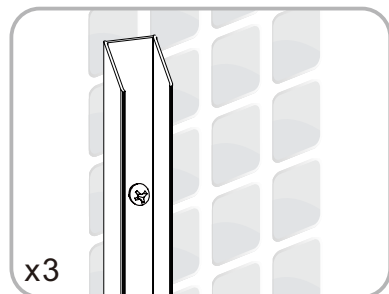
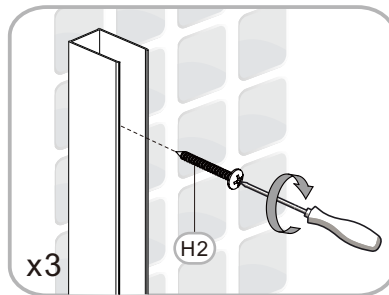
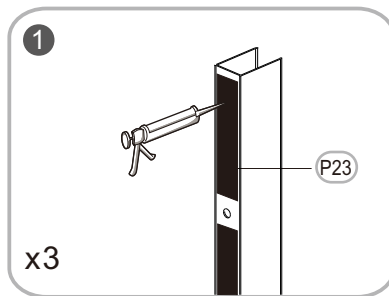
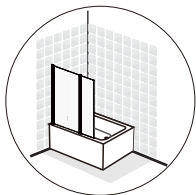

H2



x3



**B**

FR Montage

ES Montaje

PT Montagem

IT Montaggio

EL Συναρμολόγηση

PL Montaż

RU Сборка

UK Збірка

RO Montaj

EN Assembly

12

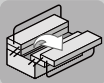
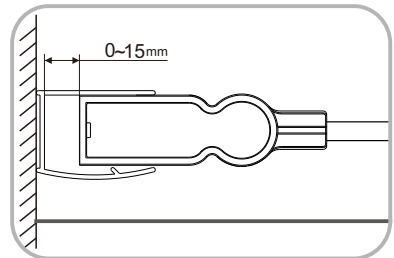
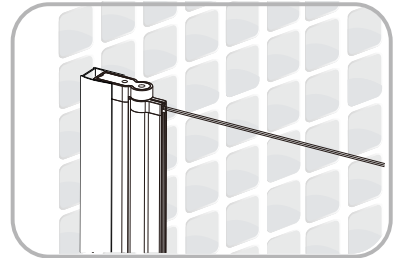
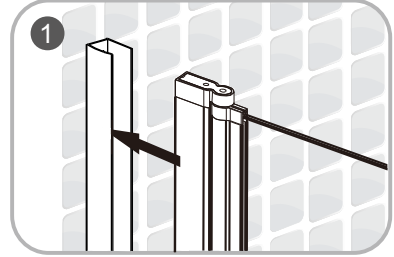
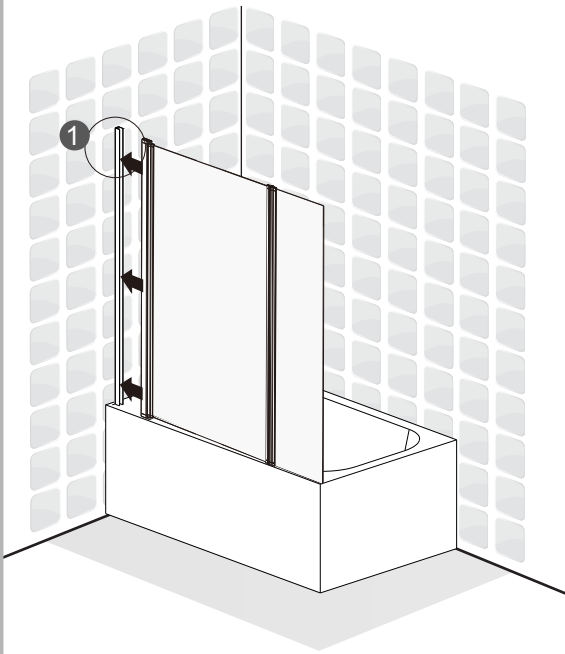
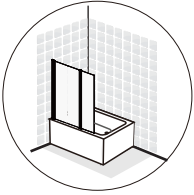

P25



x1



FR Montage

ES Montaje

PT Montagem

IT Montaggio

EL Συναρμολόγηση

PL Montaż

RU Сборка

UK Збірка

RO Montaj

EN Assembly

B

13

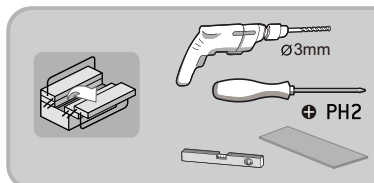
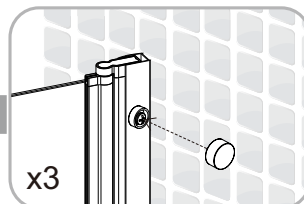
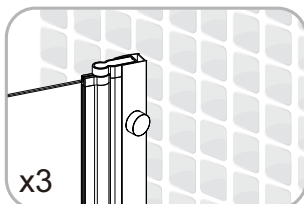
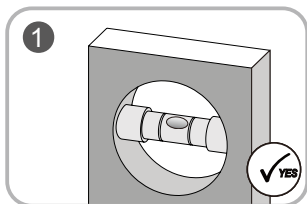
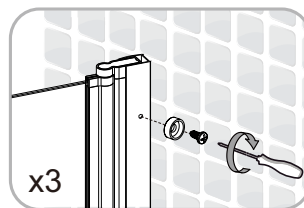
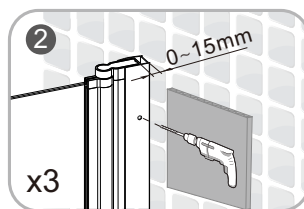
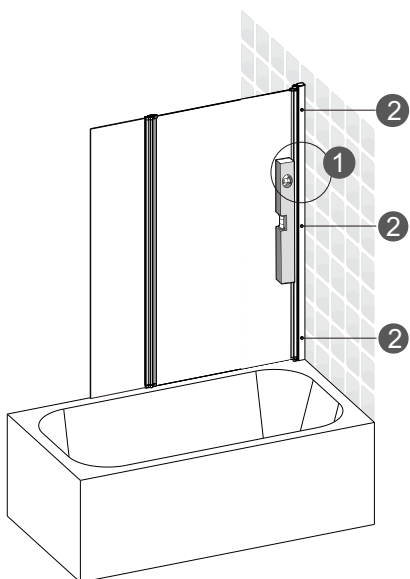
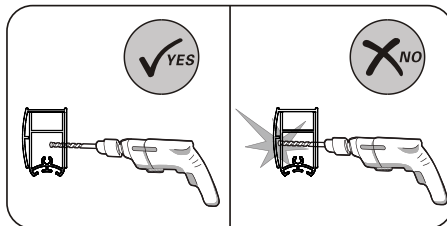
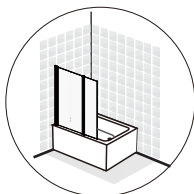

H3



x3

H14



x3

H15



x3



**B**

FR Montage

ES Montaje

PT Montagem

IT Montaggio

EL Συναρμολόγηση

PL Montaż

RU Сборка

UK Збірка

RO Montaj

EN Assembly

14

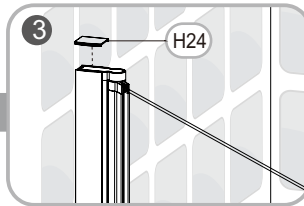
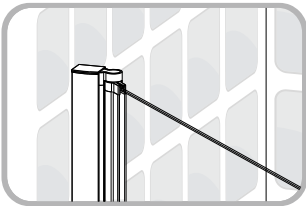
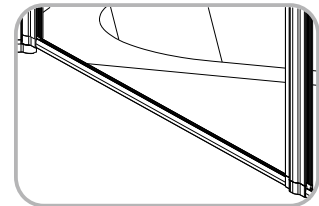
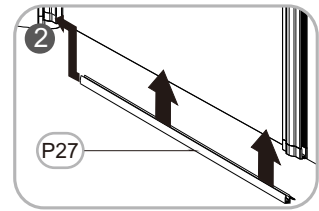
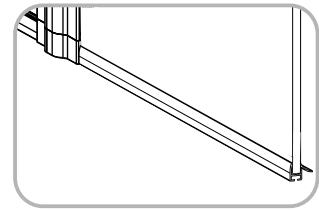
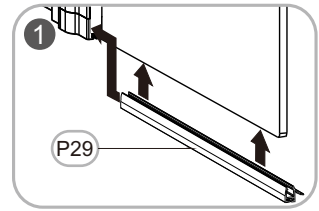
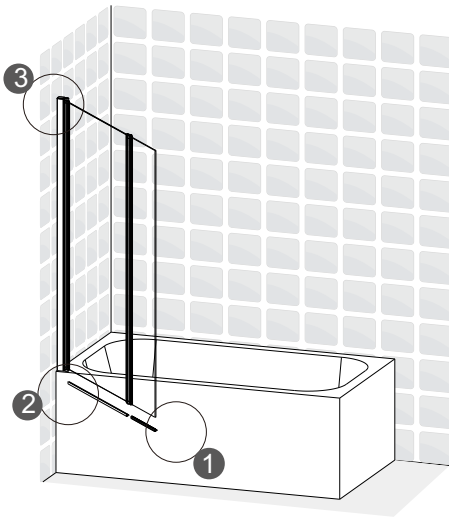
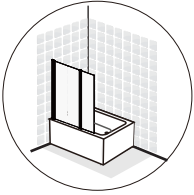

P27 ————— x1

P29 ————— x1

H24 ————— x1



FR Montage

ES Montaje

PT Montagem

IT Montaggio

EL Συναρμολόγηση

PL Montaż

RU Сборка

UK Збірка

RO Montaj

EN Assembly

B

15

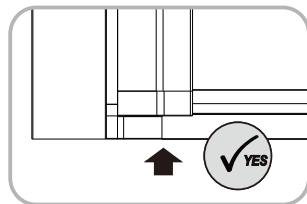
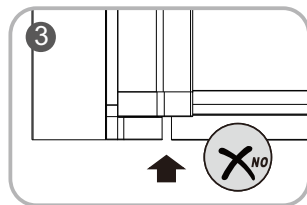
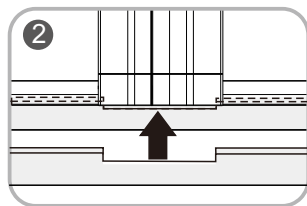
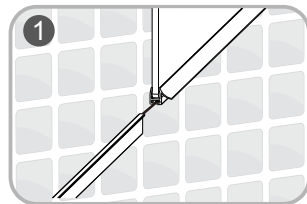
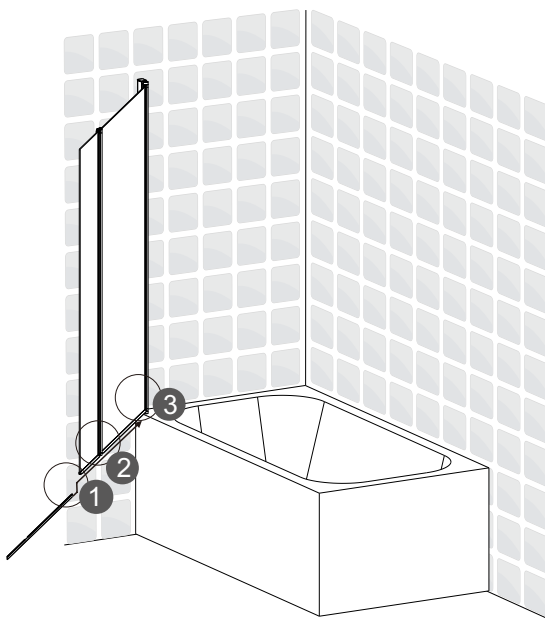
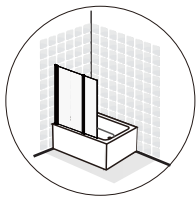

P30



x1



**B**

FR Montage

ES Montaje

PT Montagem

IT Montaggio

EL Συναρμολόγηση

PL Montaż

RU Сборка

UK Збірка

RO Montaj

EN Assembly

16

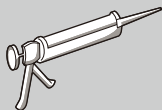
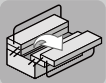
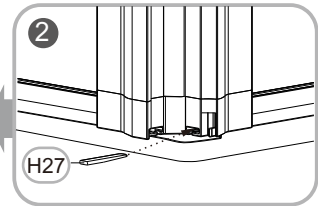
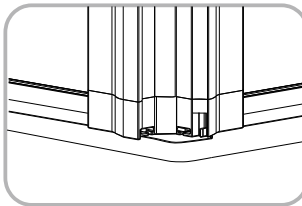
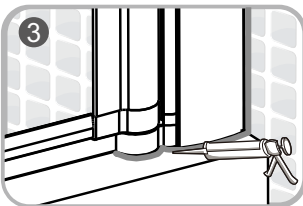
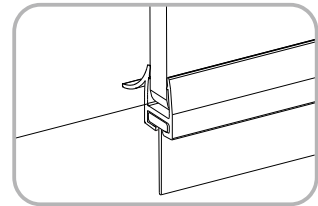
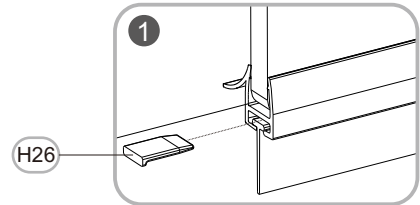
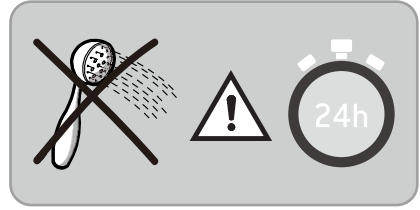
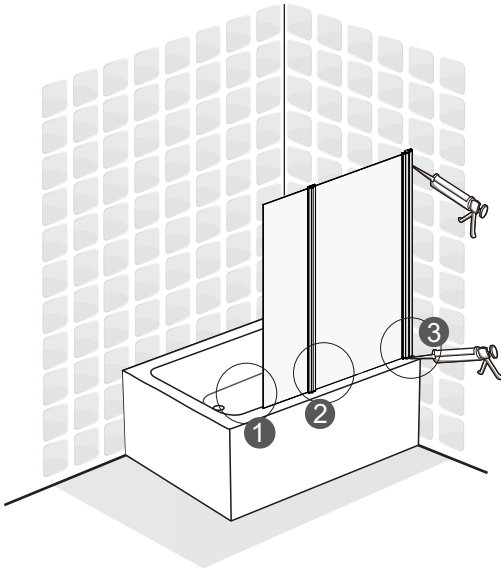

H26



x1



H27



x1

FR Entretien

ES Mantenimiento

PT Serviço

IT Manutenzione

EL Συντήρηση

PL Konserwacja

RU Уход

UK Догляд

RO Întreținere

EN Maintenance

C



Sans solvant / Sin disolvente / Sem solventes / Senza solventi / Χωρίς διαλυτικά / Bez rozpuszczalnika / Без растворителя / Без розчинника / Fără solvent / Solvent-free

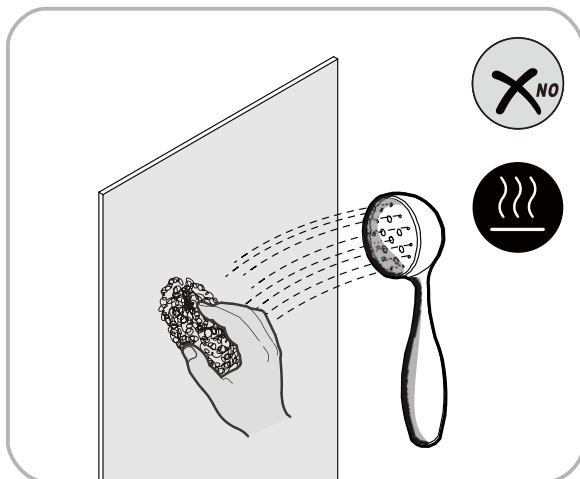
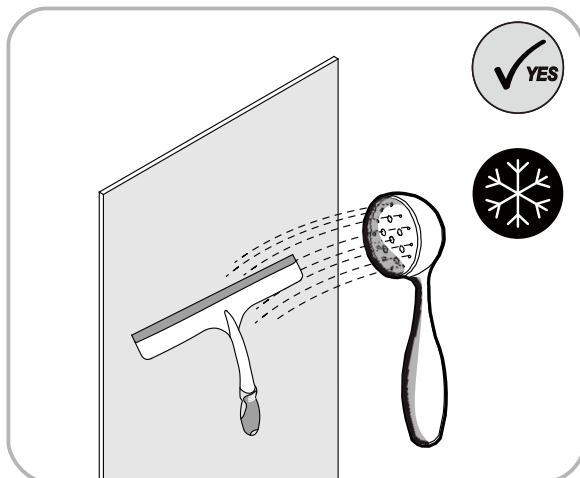

**FR**



ADEO Services  
135 Rue Sadi Carnot - CS 00001  
59790 RONCHIN - France

16  
EN 14428:2015

Code d'identification unique du produit type: **\*\***  
usage prévu: **hygiène personnelle**  
Nettoyable: **Conforme**  
Résistance à l'impact/  
Capacité de Fragmentation: **Conforme**  
durabilité: **Conforme**

DOP N° \*

**ES**



ADEO Services  
135 Rue Sadi Carnot - CS 00001  
59790 RONCHIN - France

16  
EN 14428:2015

Código de identificación única del producto tipo: **\*\***  
Uso previsto: **higiene personal**  
Limpiable: **Conforme**  
Resistencia al impacto/  
Capacidad de fragmentación: **Conforme**  
Durabilidad: **Conforme**

DOP N° \*

**PT**



ADEO Services  
135 Rue Sadi Carnot - CS 00001  
59790 RONCHIN - France

16  
EN 14428:2015

Código de identificação único do produto-tipo: **\*\***  
Utilização prevista: **higiene pessoal**  
Limpeza: **Conforme**  
Resistência ao impacto/  
Capacidade de fragmentação: **Conforme**  
Durabilidade: **Conforme**

DOP N° \*

**IT**



ADEO Services  
135 Rue Sadi Carnot - CS 00001  
59790 RONCHIN - France

16  
EN 14428:2015

Codice di identificazione unico del prodotto-tipo: **\*\***  
Uso previsto: **igiene personale**  
Pulibile: **Conforme**  
Resistenza agli urti/  
Capacità di Frammentazione: **Conforme**  
Durata: **Conforme**

DOP N° \*

**EL**



ADEO Services  
135 Rue Sadi Carnot - CS 00001  
59790 RONCHIN - France

16  
EN 14428:2015

Μοναδικός κωδικός ταυτοποίησης του τύπου του προϊόντος: **\*\***  
προβλεπόμενη χρήση: **προσωπική υγιεινή**  
«νασιτότητα καθαρισμού»: **Σύμφωνος με**  
Αντοχή σε κρούση/  
Ικανότητα κατάτμησης: **Σύμφωνος με**  
«ίαρκεια»: **Σύμφωνος με**

DOP N° \*

**PL**



ADEO Services  
135 Rue Sadi Carnot - CS 00001  
59790 RONCHIN - France

16  
EN 14428:2015

Niepotwarzalny kod identyfikacyjny typu wyrobu: **\*\***  
przeznaczenie: **higiiena osobista**  
Możliwość czyszczenia: **Zgodny**  
Odporność na uderzenia/  
Rozkruszalność: **Zgodny**  
Trwałość: **Zgodny**

DOP N° \*

**RU**



ADEO Services  
135 Rue Sadi Carnot - CS 00001  
59790 RONCHIN - France

16  
EN 14428:2015

Уникальный идентификационный код типа изделия: **\*\***  
Назначение: **личная гигиена**  
Легкость очистки: **Соответствие**  
Ударопрочность/  
Мощность распыления: **Соответствие**  
Долговечность: **Соответствие**

DOP N° \*

**UK**



ADEO Services  
135 Rue Sadi Carnot - CS 00001  
59790 RONCHIN - France

16  
EN 14428:2015

Унікальний ідентифікаційний код виду продукції: **\*\***  
призначення: **особиста гігієна**  
Легкість очищення: **Відповідність**  
Ударостійкість/  
Потужність розпилення: **Відповідність**  
Довговічність: **Відповідність**

DOP N° \*

**RO**



ADEO Services  
135 Rue Sadi Carnot - CS 00001  
59790 RONCHIN - France

16  
EN 14428:2015

Cod unic de identificare a tipului de produs: **\*\***  
destinație: **higiенă personală**  
Posibilitatea de curățare: **Conform**  
Rezistență la impact/  
Capacitate de fragmentare: **Conform**  
Durabilitate: **Conform**

DOP N° \*

**EN**



ADEO Services  
135 Rue Sadi Carnot - CS 00001  
59790 RONCHIN - France

16  
EN 14428:2015

Unique identification code of the product-type: **\*\***  
Intended use: **personal hygiene**  
cleanability: **Pass**  
Impact resistance/ shatter properties: **Pass**  
Durability: **Pass**

DOP N° \*

- \*\***
- FR** Reportez-vous à läänexxe.
  - ES** Consulte el apéndice.
  - PT** Consulte o anexo.
  - IT** Consultare lääppendice.
  - EL** Ανατρέξτε στο Παράρτημα.
  - PL** Patrz załącznik.
  - RU** См. приложение.
  - UK** Читайте додаток.
  - RO** Consultați anexa.
  - EN** Refer to appendix.









ADEO Services  
135 Rue Sadi Carnot  
CS 00001  
59790 RONCHIN - France

ТОВ «Леруа Мерлен Україна»,  
вул. Полярна 17а, м. Київ  
04201, Україна

ООО ЛЕРУА МЕРЛЕН ВОСТОК,  
141031, Московская область,  
Мытищинский район, г. Мытищи,  
Осташковское шоссе, д.1, РОССИЯ

\* Garantie 2 ans / Garantía 2 años / Garantia 2 anos / Garanzia 2 anni  
Εγγύηση 2 ετών / Gwarancja 2 lat / 2 летняя / 2-річна гарантія  
2 ani garanție / Guarantee 2 years

Made In P.R.C. 2016